

# GS CONNECTOR SERIES

*D-Sub Rectangular I/O Connectors*

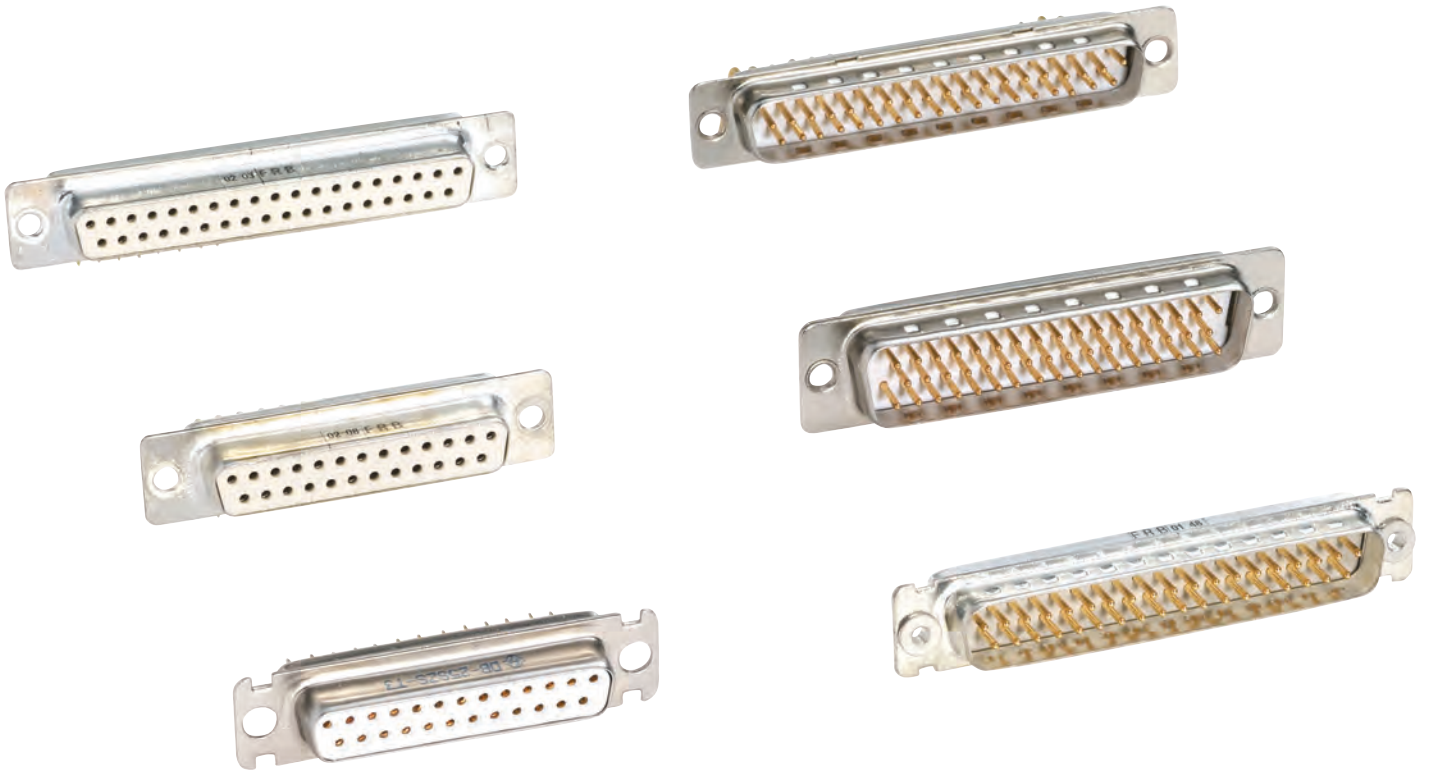

# HYPERBOLOID TECHNOLOGY

Smiths Connectors offers an extensive range of superior contact technologies suitable for standard and custom solutions. Hypertac® (HYPERboloid conTACT) is the original superior performing hyperboloid contact technology designed for use in all applications and in harsh and demanding environments where high reliability and safety are critical. The inherent electrical and mechanical characteristics of the Hypertac hyperboloid contact ensures unrivalled performance in terms of reliability, number of mating cycles, low contact force and minimal contact resistance. The shape of the contact sleeve is formed by hyperbolically arranged contact wires, which align themselves elastically as contact lines around the pin, providing a number of linear contact paths.

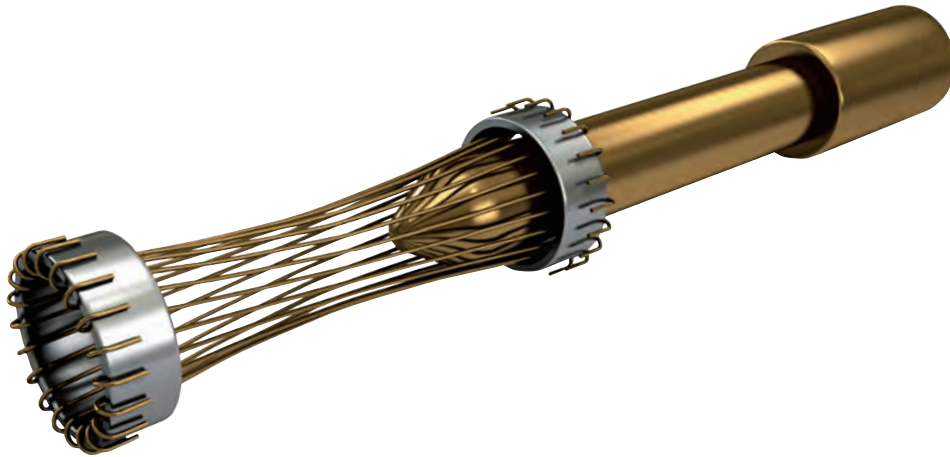

## FEATURE

### LOW INSERTION/EXTRACTION FORCES

The angle of the socket wires allows tight control of the pin insertion and extraction forces. The spring wires are smoothly deflected to make line contact with the pin.

### LONG CONTACT LIFE

The smooth and light wiping action minimizes wear on the contact surfaces. Contacts perform up to 100,000 insertion/extraction cycles with minimal degradation in performance.

### LOWER CONTACT RESISTANCE

The design provides a far greater contact area and the wiping action of the wires insures a clean and polished contact surface. Our contact technology has about half the resistance of conventional contact designs.

### HIGHER CURRENT RATINGS

The design parameters of the contact (e.g., the number, diameter and angle of the wires) may be modified for any requirement. The number of wires can be increased so the contact area is distributed over a larger surface. Thus, the high current carried by each wire because of its intimate line contact, can be multiplied many times.

### IMMUNITY TO SHOCK & VIBRATION

The low mass and resultant low inertia of the wires enable them to follow the most abrupt or extreme excursions of the pin without loss of contact. The contact area extends 360° around the pin and is uniform over its entire length. The 3 dimensional symmetry of the Hypertac contact design guarantees electrical continuity in all circumstances.

## BENEFIT

### HIGH DENSITY INTERCONNECT SYSTEMS

Significant reductions in size and weight of sub-system designs. No additional hardware is required to overcome mating and un-mating forces.

### LOW COST OF OWNERSHIP

The Hypertac contact technology will surpass most product requirements, thus eliminating the burden and cost of having to replace the connector or the entire subsystem.

### LOW POWER CONSUMPTION

The lower contact resistance of our technology results in a lower voltage drop across the connector reducing the power consumption and heat generation within the system.

### MAXIMUM CONTACT PERFORMANCE

The lower contact resistance of the Hypertac contact reduces heat build-up; therefore Hypertac contacts are able to handle far greater current in smaller contact assemblies without the detrimental effects of high temperature.

### RELIABILITY UNDER HARSH ENVIRONMENTS

Harsh environmental conditions require connectors that will sustain their electrical integrity even under the most demanding conditions such as shock and vibration. The Hypertac contact provides unmatched stability in demanding environments when failure is not an option.

# TABLE OF CONTENTS

## GS SERIES - D-SUB

▶ Technical characteristics .....	2
▶ How to order .....	3
▶ 90° PC tail .....	4
▶ Straight PC tail .....	6
▶ Solder cup terminations .....	8
▶ Crimp terminations .....	10
▶ Mounting .....	13
▶ Hoods with screw locks .....	14
▶ Accessories and tools .....	15
▶ Board preparation details .....	17

## GSF SERIES - D-SUB CODED

▶ Technical characteristics .....	18
▶ How to order .....	18
▶ Connector dimensions .....	19
▶ Coding system .....	20
▶ Example of coding .....	21
▶ Hood accessories .....	23

# TECHNICAL CHARACTERISTICS

MATERIAL		GENERAL																
Shell	Plated steel	<table border="1"> <tr> <td>Number of contacts</td> <td>9</td> <td>15</td> <td>25</td> <td>37</td> <td>50</td> </tr> <tr> <td>Shell</td> <td>E</td> <td>A</td> <td>B</td> <td>C</td> <td>D</td> </tr> </table>					Number of contacts	9	15	25	37	50	Shell	E	A	B	C	D
Number of contacts	9						15	25	37	50								
Shell	E	A	B	C	D													
Insulator	PBT (15%) UL94V0																	
Socket wires	Copper alloy	Contact	Ø 1.02															
Pin & socket body	Brass	Pitch between contacts	2.74 mm (9 & 15 contacts) 2.77 mm (25, 37 & 50 contacts)															
Plastic hood	ABS, UL94V0	Pitch between rows	2.84 mm															
Metallic plastic hood	Metallic ABS, UL94V0	Crimp termination	AWG 20-22-24 (0.22 to 0.60 mm <sup>2</sup> ) AWG 26-28 (0.093 to 0.14 mm <sup>2</sup> )															
Metallic hood	Aluminum alloy																	

PLATING		ENVIRONMENTAL	
Terminations and contact areas	Au/Ni	Temperature range	-55° C, +125° C
Shell	Tinned shell	Salt spray	48 h
		Dry heat	1 000h/at +125° C
		Damped heat	56 days (40° C, relative humidity: 90-95%)

ELECTRICAL		MECHANICAL	
Working voltage	300 VAC	Contact retention	20 N min (max displacement: 0.3 mm)
Current rating	7.5 A	Mating and unmating cycles	5.000
Dielectric withstanding voltage	1.000 Vrms	Vibrations and shocks	
Electric continuity (shell to shell)*	2 mΩ / typical	- Sinusoidal vibrations	No discontinuity ≥ 20ns
Contact resistance	5 mΩ max / standard value 8 mΩ max	- Shocks	10/2.000 Hz, 1.5 mm, 20 g
Insulation resistance	≥ 5.10 <sup>3</sup> MΩ max		50 g

## INSULATOR RETENTION IN HOUSING

Number of contacts	9	15	25	37	50
Shell	E	A	B	C	D
Min retention	53 N	80 N	124 N	180 N	233 N

\* Only for tin plated shells with dimples

# HOW TO ORDER

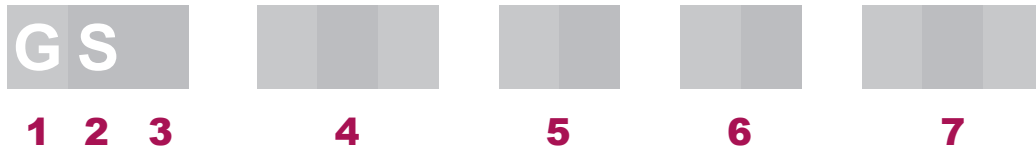

## 1 ▶ CONNECTOR FAMILY

## 2 ▶ MODEL

## 3 ▶ SHELL STYLE

- TIN PLATED SHELL\* (salt spray 48 h)    D ZINC CHROMATE PLATED SHELL\*\* (salt spray 500 h)

## 4 ▶ LAYOUT

009    015    025    037    055

## 5 ▶ PART - POLARITY - PLATING

00 DELIVERED WITHOUT CONTACT    13 MALE PLUG, GOLD PLATED TERMINATION  
 1B MALE PLUG, PRETINNED TERMINATION\*\*\*    22 FEMALE RECEPTACLE, GOLD PLATED TERMINATION  
 2A FEMALE RECEPTACLE, PRETINNED TERMINATION\*\*\*

## 6 ▶ TERMINATIONS

10 RIGHT ANGLE TERMINATION    20 CRIMP CONTACTS AWG 20 TO 24    22 CRIMP CONTACTS AWG 26 TO 28  
 30 STRAIGHT TERMINATION    40 SOLDER CUP TERMINATION

## 7 ▶ MOUNTING

110 MOUNTING FOR D-SUB 90° (M3-6G)    150 FLOAT MOUNTING    111 RIGHT ANGLE D-SUB MOUNTING

\* male plug with dimples

\*\* male plug without dimples

\*\*\* only for PC tail terminations

The other accessories are sold separately.

Sealed connectors: consult us.

▶ 90° PC TAIL PLUGS

PIN

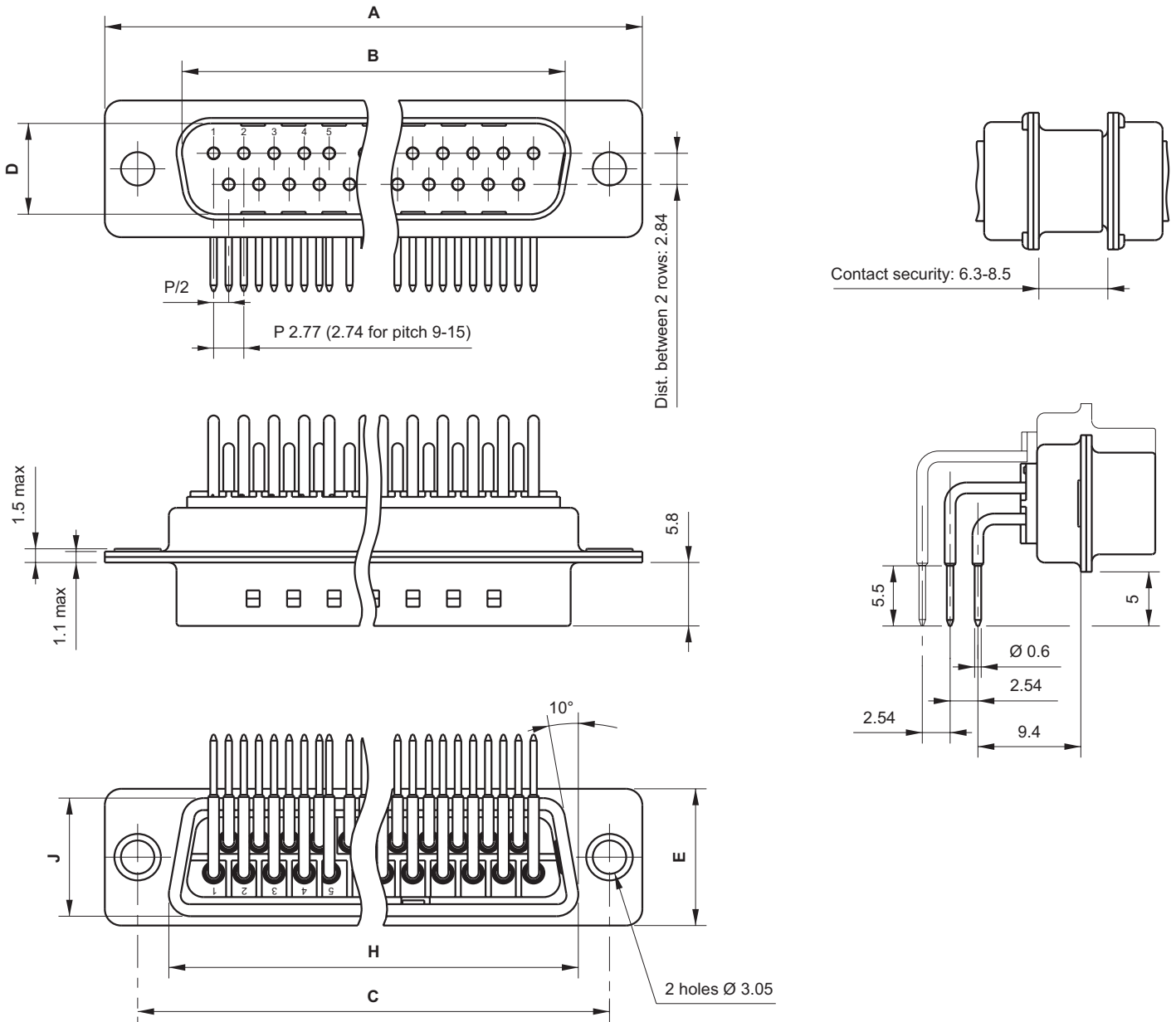

Part Number	No. of contacts	Dimensions (mm)						
		A (± 0.2)	B (± 0.2)	C (± 0.2)	D (± 0.2)	E (± 0.2)	H (± 0.2)	J (± 0.2)
GS-009..10...	9	30.70	16.90	25.00	8.40	12.30	19.30	10.80
GS-015..10...	15	39.10	25.20	33.30	8.40	12.30	27.50	10.80
GS-025..10...	25	52.90	38.90	47.05	8.40	12.30	41.30	10.80
GS-037..10...	37	69.30	55.40	63.50	8.40	12.30	57.70	10.80
GS-050..10...	50	66.70	52.80	61.10	11.20	15.30	55.30	13.60

► 90° PC TAIL RECEPTACLES

SOCKET

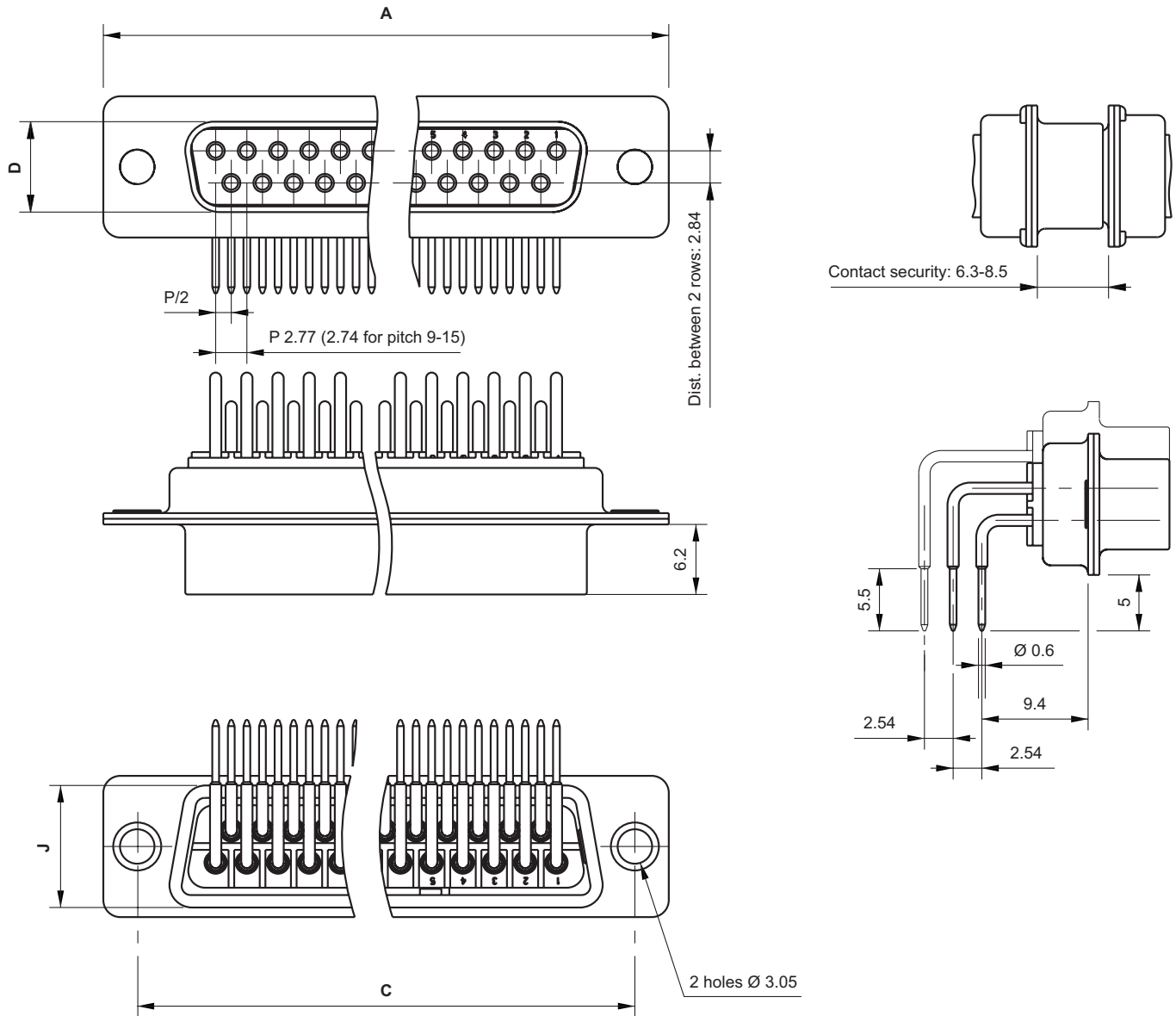

Part Number	No. of contacts	Dimensions (mm)						
		A (± 0.2)	B (± 0.2)	C (± 0.2)	D (± 0.2)	E (± 0.2)	H (± 0.2)	J (± 0.2)
GS-009..10...	9	30.70	16.20	25.00	7.80	12.30	19.30	10.80
GS-015..10...	15	39.10	24.70	33.30	7.80	12.30	27.50	10.80
GS-025..10...	25	52.90	38.40	47.05	7.80	12.30	41.30	10.80
GS-037..10...	37	69.30	54.70	63.50	7.80	12.30	57.70	10.80
GS-050..10...	50	66.70	52.30	61.10	10.80	15.30	55.30	13.60

► STRAIGHT PC TAIL PLUGS

PIN

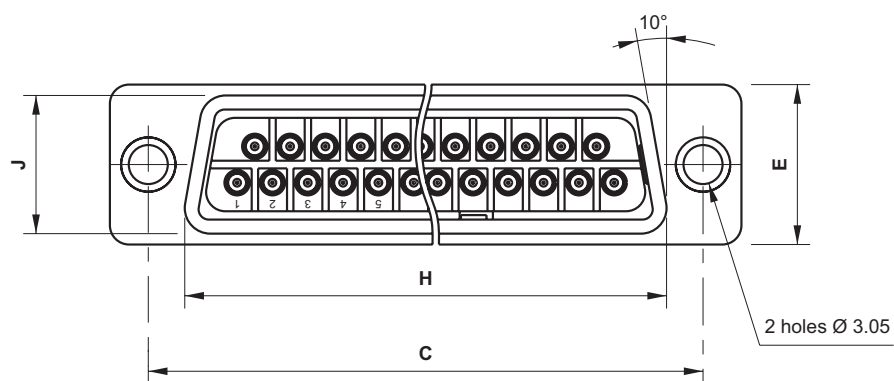
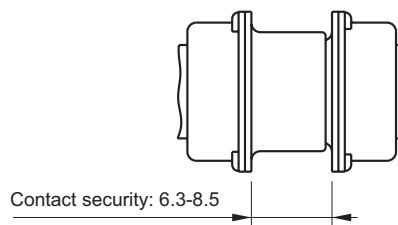
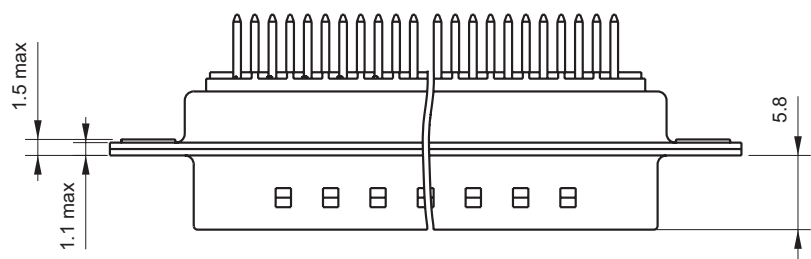
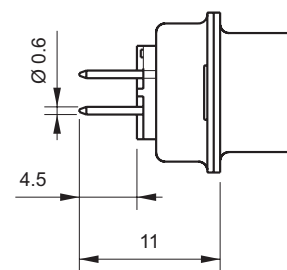
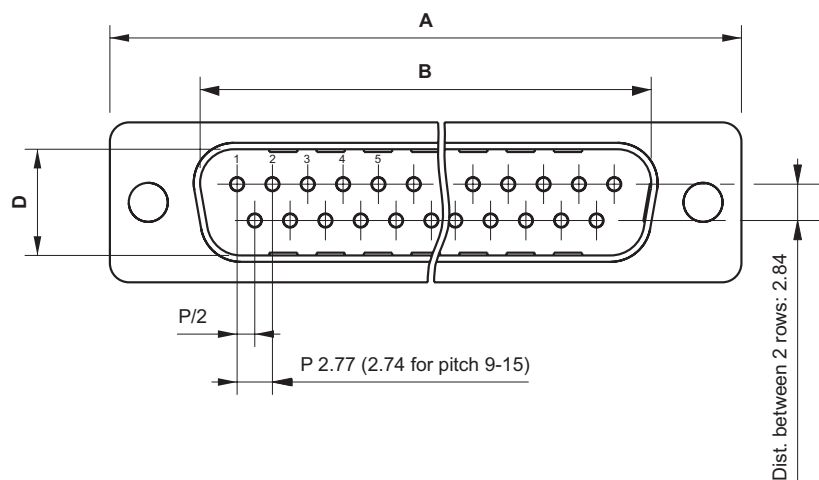

Part Number	No. of contacts	Dimensions (mm)						
		A (± 0.2)	B (± 0.2)	C (± 0.2)	D (± 0.2)	E (± 0.2)	H (± 0.2)	J (± 0.2)
GS-009..30...	9	30.70	16.90	25.00	8.40	12.30	19.30	10.80
GS-015..30...	15	39.10	25.20	33.30	8.40	12.30	27.50	10.80
GS-025..30...	25	52.90	38.90	47.05	8.40	12.30	41.30	10.80
GS-037..30...	37	69.30	55.40	63.50	8.40	12.30	57.70	10.80
GS-050..30...	50	66.70	52.80	61.10	11.20	15.30	55.30	13.60



► STRAIGHT PC TAIL RECEPTACLES

SOCKET

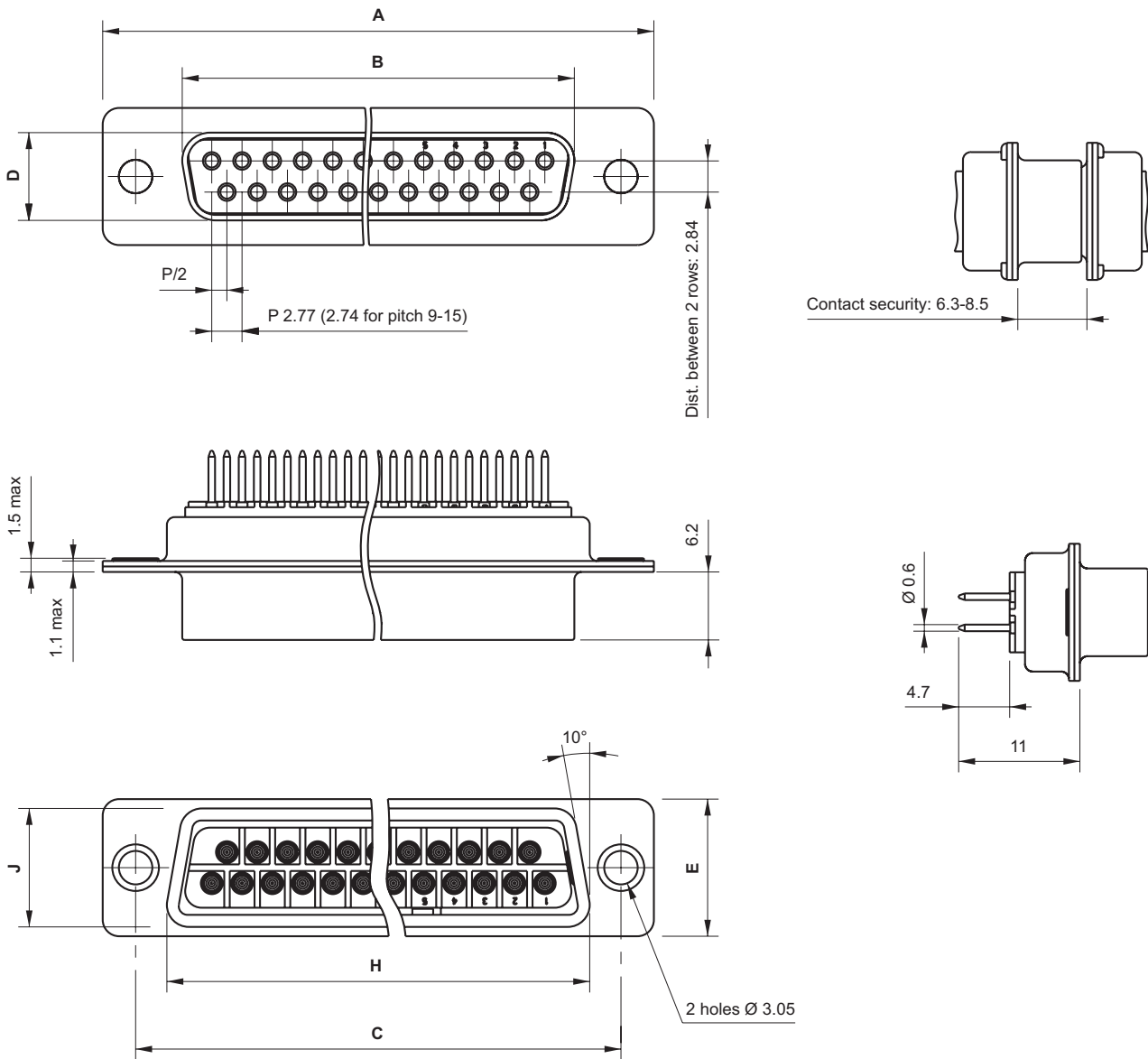

Part Number	No. of contacts	Dimensions (mm)						
		A (± 0.2)	B (± 0.2)	C (± 0.2)	D (± 0.2)	E (± 0.2)	H (± 0.2)	J (± 0.2)
GS-009..30...	9	30.70	16.20	25.00	7.80	12.30	19.30	10.80
GS-015..30...	15	39.10	24.70	33.30	7.80	12.30	27.50	10.80
GS-025..30...	25	52.90	38.40	47.05	7.80	12.30	41.30	10.80
GS-037..30...	37	69.30	54.70	63.50	7.80	12.30	57.70	10.80
GS-050..30...	50	66.70	52.30	61.10	10.80	15.30	55.30	13.60

► SOLDER CUP TERMINATION PLUGS

PIN

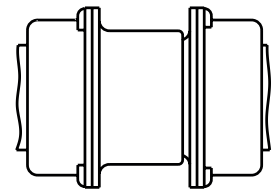
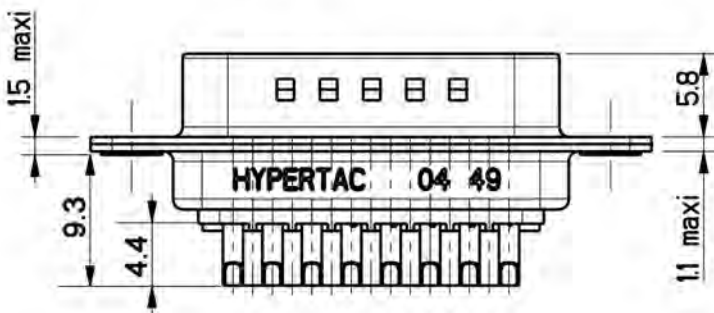
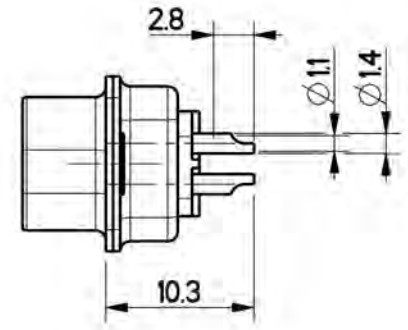
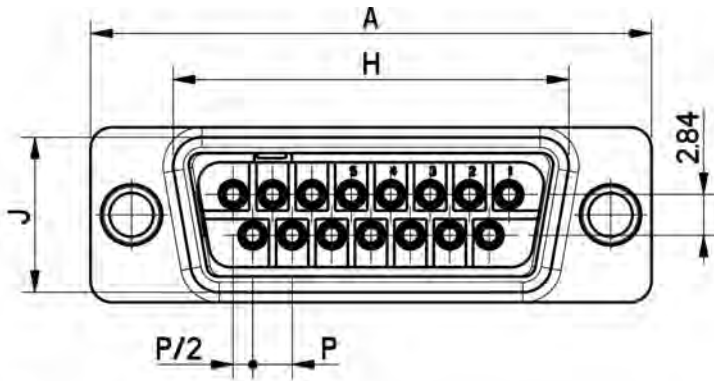

Contact security: 6.3-8.5

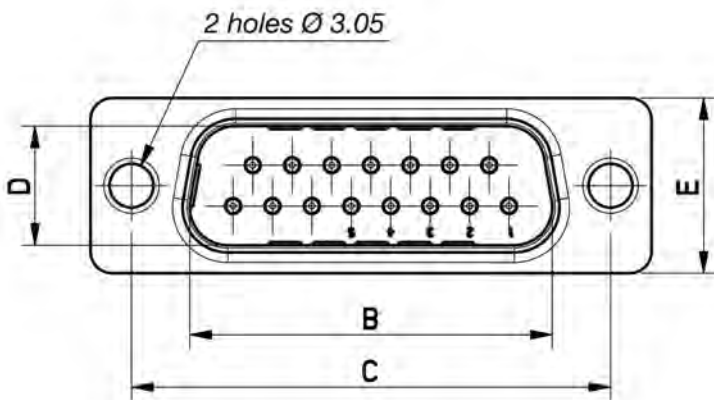

Part Number	No. of contacts	Dimensions (mm)						
		A (± 0.2)	B (± 0.2)	C (± 0.2)	D (± 0.2)	E (± 0.2)	H (± 0.2)	J (± 0.2)
GS-009..40...	9	30.70	16.90	25.00	8.40	12.30	19.30	10.80
GS-015..40...	15	39.10	25.20	33.30	8.40	12.30	27.50	10.80
GS-025..40...	25	52.90	38.90	47.05	8.40	12.30	41.30	10.80
GS-037..40...	37	69.30	55.40	63.50	8.40	12.30	57.70	10.80
GS-050..40...	50	66.70	52.80	61.10	11.20	15.30	55.30	13.60

► SOLDER CUP TERMINATION RECEPTACLES

SOCKET

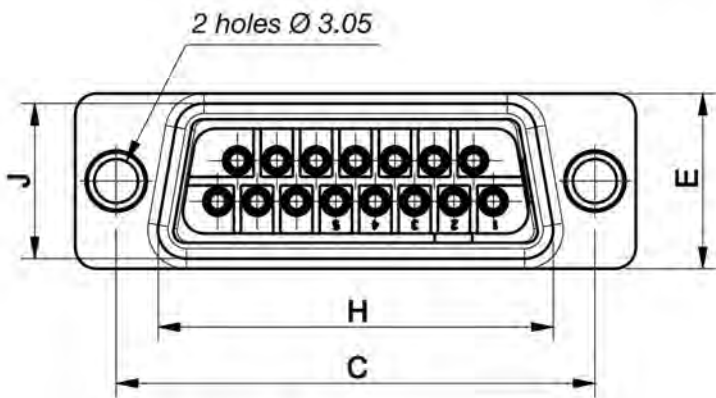
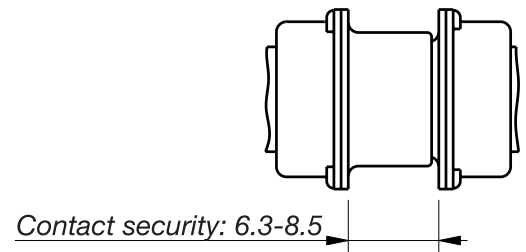
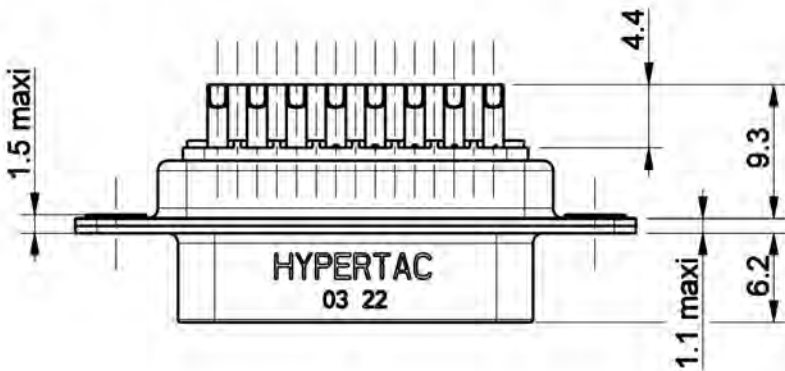
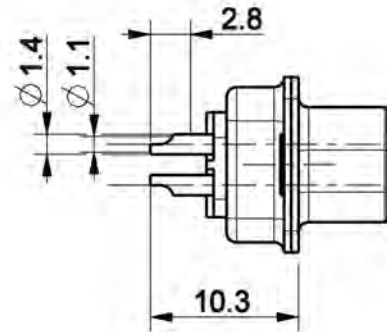
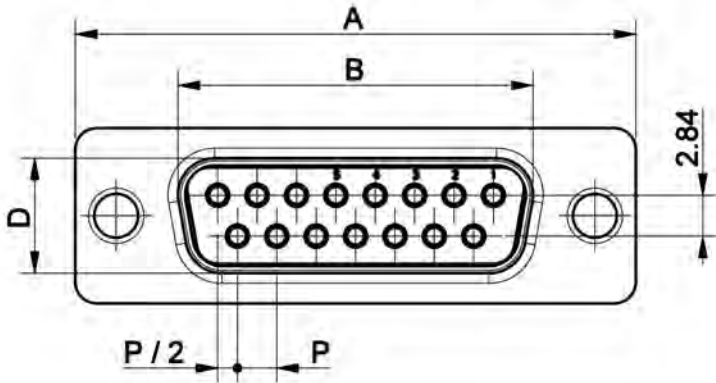

Part Number	No. of contacts	Dimensions (mm)						
		A (± 0.2)	B (± 0.2)	C (± 0.2)	D (± 0.2)	E (± 0.2)	H (± 0.2)	J (± 0.2)
GS-009..40...	9	30.70	16.20	25.00	7.80	12.30	19.30	10.80
GS-015..40...	15	39.10	24.70	33.30	7.80	12.30	27.50	10.80
GS-025..40...	25	52.90	38.40	47.05	7.80	12.30	41.30	10.80
GS-037..40...	37	69.30	54.70	63.50	7.80	12.30	57.70	10.80
GS-050..40...	50	66.70	52.30	61.10	10.80	15.30	55.30	13.60

► CRIMP TERMINATION PLUGS

PIN

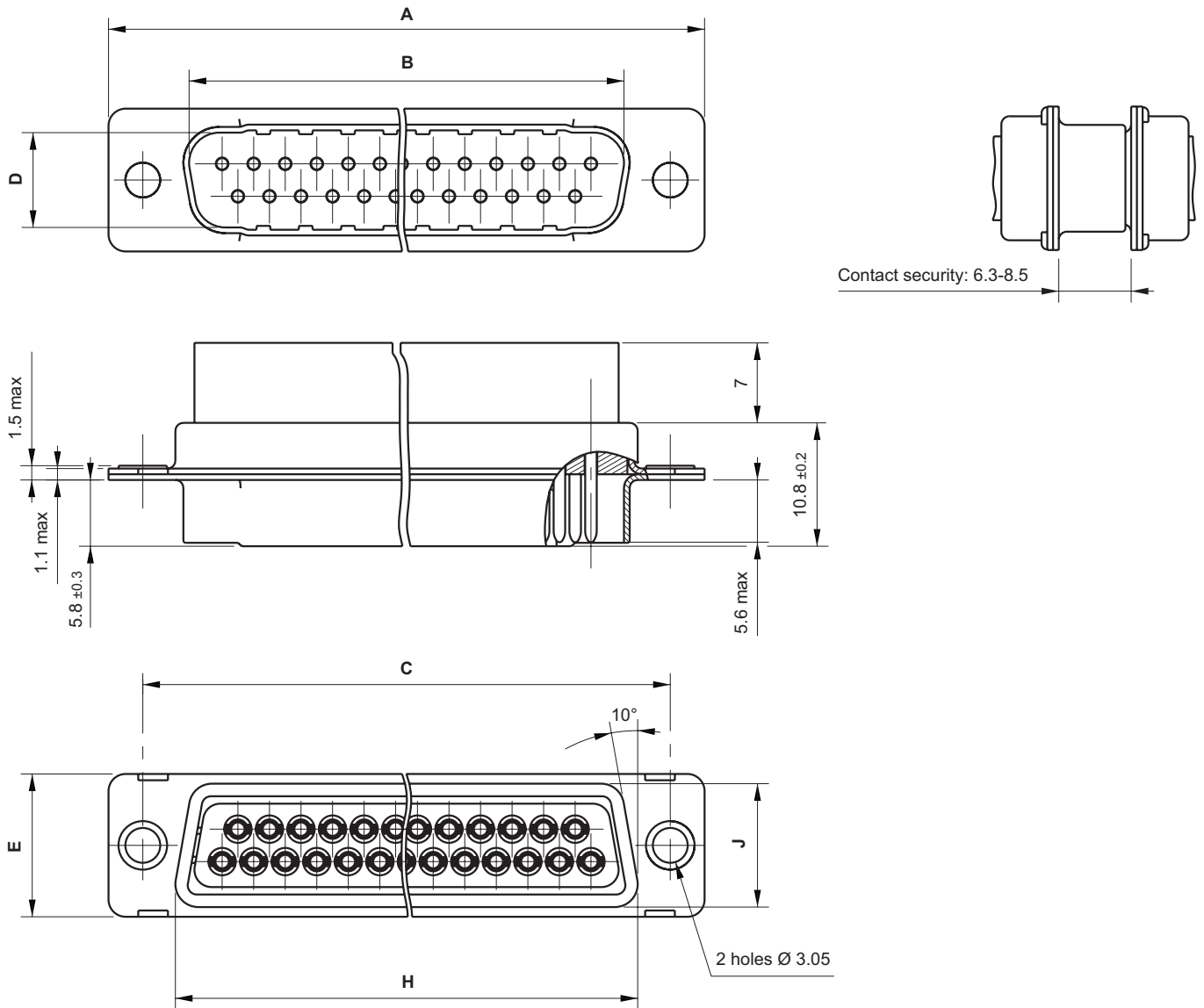

Contact security: 6.3-8.5

Part Number	No. of contacts	Dimensions (mm)						
		A (± 0.2)	B (± 0.2)	C (± 0.2)	D (± 0.2)	E (± 0.2)	H (± 0.2)	J (± 0.2)
GS-009 13 2	9	30.80	16.80	25.00	8.30	12.50	19.30	10.80
GS-015 13 2	15	39.10	25.10	33.30	8.30	12.50	27.50	10.80
GS-025 13 2	25	53.00	38.90	47.00	8.30	12.50	41.30	10.80
GS-037 13 2	37	69.30	55.30	63.50	8.30	12.50	57.70	10.80
GS-050 13 2	50	67.00	52.70	61.10	11.00	15.40	55.30	13.60

## ► CRIMP TERMINATION RECEPTACLES

### SOCKET

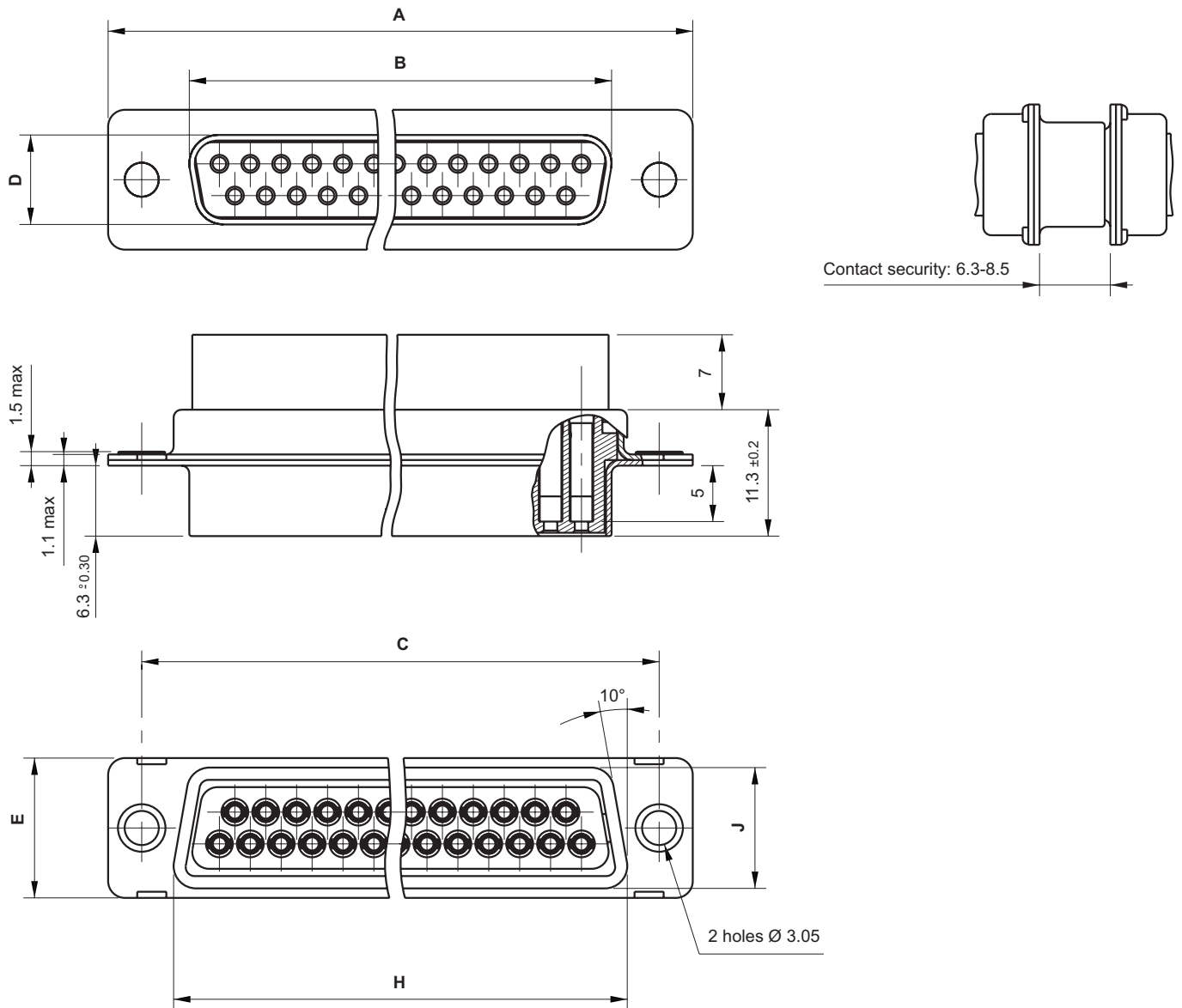

Part Number	No. of contacts	Dimensions (mm)						
		A (± 0.2)	B (± 0.2)	C (± 0.2)	D (± 0.2)	E (± 0.2)	H (± 0.2)	J (± 0.2)
GS-009 22 2	9	30.80	16.40	25.00	8.00	12.50	19.30	10.80
GS-015 22 2	15	39.10	24.70	33.30	8.00	12.50	27.50	10.80
GS-025 22 2	25	53.00	38.50	47.00	8.00	12.50	41.30	10.80
GS-037 22 2	37	69.30	54.90	63.50	8.00	12.50	57.70	10.80
GS-050 22 2	50	67.00	52.50	61.10	10.80	15.40	55.30	13.60

► CRIMP TERMINATION CONTACTS

PIN

HYPERBOLOID SOCKET

Ø 1.02, AWG 24 TO 20

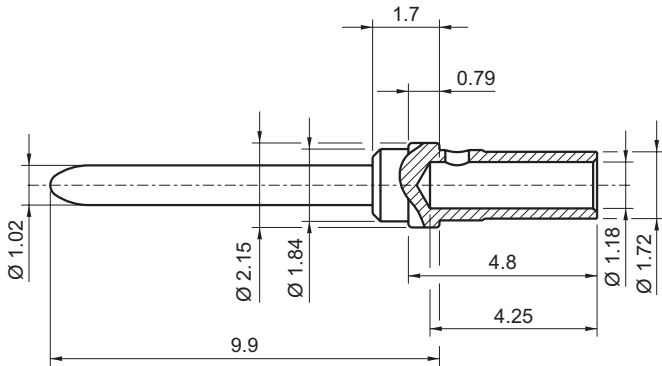

Ref: 010 090 1- 20- OG\*

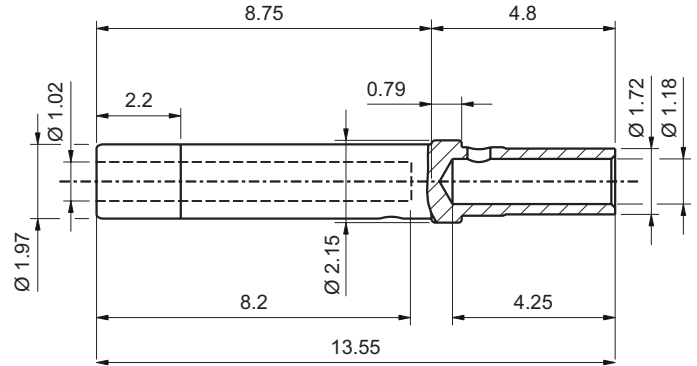

Ref: 010 090 2- 20- OG\*

Ø 1.02, AWG 28 TO 26

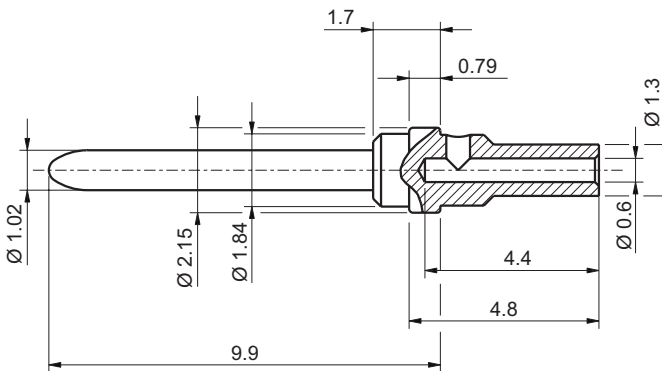

Ref: 010 093 1- 22- OG\*

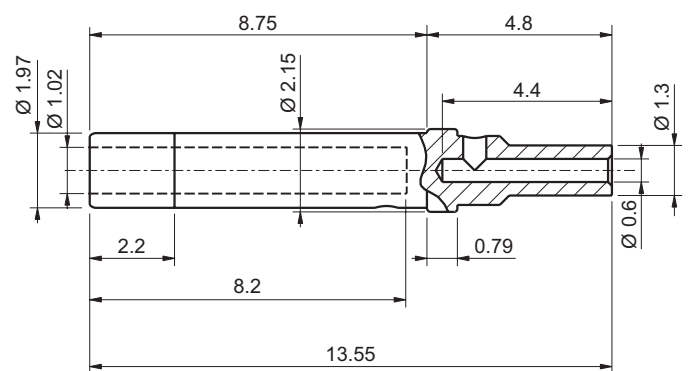

Ref: 010 093 2- 20- OG\*

\* for spares parts

► MOUNTING

FLOAT MOUNTING

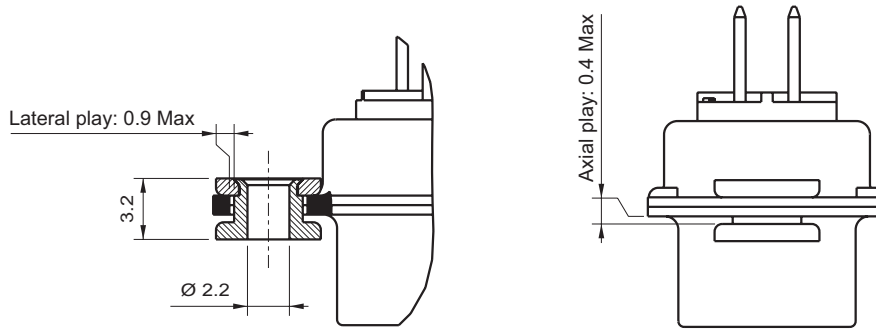

Ref: GS- - - - - 150

BRACKET AND SCREW FOR D-SUB 90°

Shell E, A, B, C

Shell D

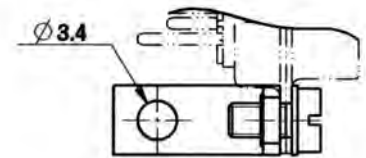
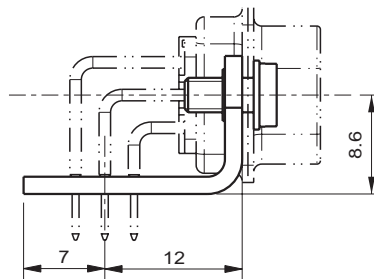
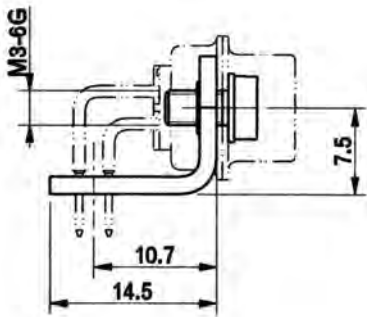

Ref: GS- - - - - 110

BRACKET AND FEMALE SCREW LOCK FOR D-SUB 90°

Shell E, A, B, C

Shell D

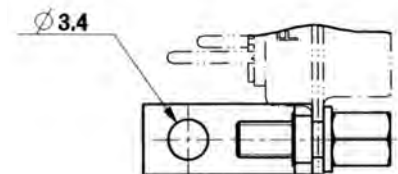
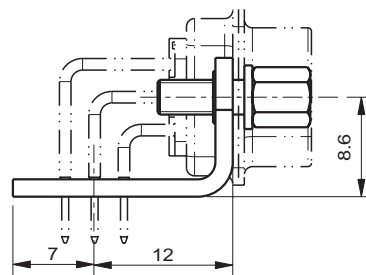
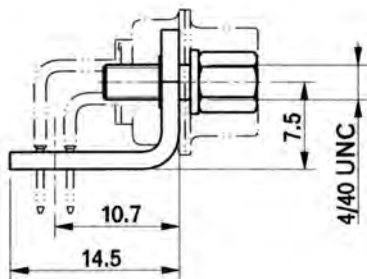

Ref: GS- - - - - 111

► HOODS WITH SCREW LOCKS

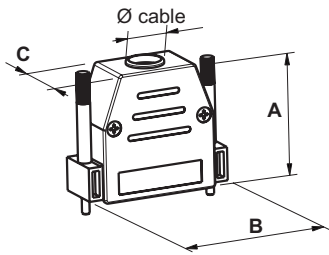

PLASTIC 38 MM SCREWS

Part Number	Dimensions (mm)			Ø Cable
	A	B	C	
GS-009 300	31.00	31.50	15.20	8.50
GS-015 300	35.00	40.00	15.20	8.50
GS-025 300	38.00	53.50	15.20	11.00
GS-037 300	40.00	70.00	15.20	11.00
GS-050 300	40.00	67.50	18.20	12.00

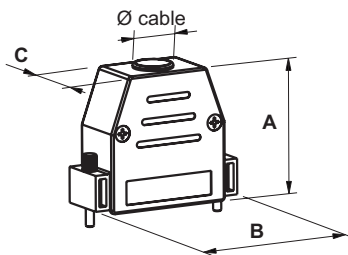

PLASTIC 18 MM SCREWS

Part Number	Dimensions (mm)			Ø Cable
	A	B	C	
GS-009 301	31.00	31.50	15.20	8.50
GS-015 301	35.00	40.00	15.20	8.50
GS-025 301	38.00	53.50	15.20	11.00
GS-037 301	40.00	70.00	15.20	11.00
GS-050 301	40.00	67.50	18.20	12.00

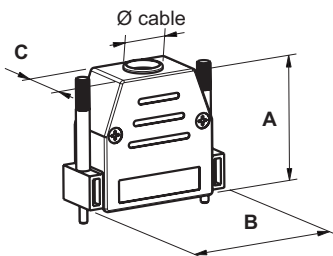

METALLIZED PLASTIC 38 MM SCREWS

Part Number	Dimensions (mm)			Ø Cable
	A	B	C	
GS-009 302	31.00	31.50	15.20	8.50
GS-015 302	35.00	40.00	15.20	8.50
GS-025 302	38.00	53.50	15.20	11.00
GS-037 302	40.00	70.00	15.20	11.00
GS-050 302	40.00	67.50	18.20	12.00

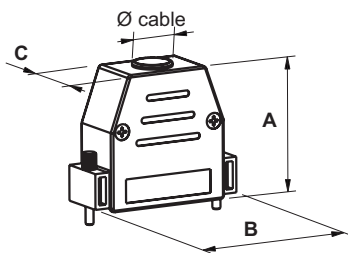

METALLIZED PLASTIC 18 MM SCREWS

Part Number	Dimensions (mm)			Ø Cable
	A	B	C	
GS-009 303	31.00	31.50	15.20	8.50
GS-015 303	35.00	40.00	15.20	8.50
GS-025 303	38.00	53.50	15.20	11.00
GS-037 303	40.00	70.00	15.20	11.00
GS-050 303	40.00	67.50	18.20	12.00

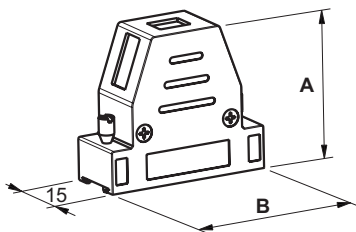

DIECAST HOOD WITH SCREW LOCKS

Part Number	Dimensions (mm)	
	A	B
GS-009 304	38.00	31.00
GS-015 304	35.00	39.50
GS-025 304	43.00	53.00

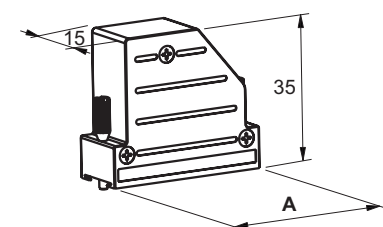

DIECAST HOOD WITH SIDE CABLE OUTPUT AND SCREW LOCKS

Part Number	Dimensions (mm)
	A
GS-009 305	31.00
GS-015 305	39.30
GS-025 305	53.00



▶ ACCESSORIES

CRIMP SLEEVE

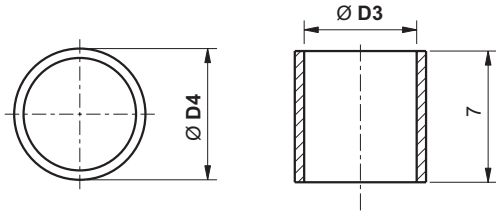

Part Number	Dimensions (mm)	
	Ø D3	Ø D4
GS-060 307	6.00	7.00
GS-065 307	6.50	7.50
GS-075 307	7.50	8.50
GS-080 307	8.00	9.00
GS-100 307	10.00	11.00
GS-105 307	10.50	11.50
GS-110 307	11.00	12.00
GS-115 307	11.50	12.50
GS-120 307	12.00	13.00
GS-140 307	14.00	15.00

CRIMP FLANGE

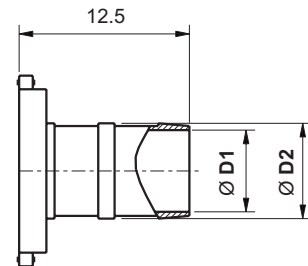

Part Number	Dimensions (mm)	
	Ø D1	Ø D2
GS-030 306	3.00	4.00
GS-035 306	3.5	4.50
GS-045 306	4.5	5.50
GS-050 306	5.00	6.00
GS-060 306	6.00	7.00
GS-070 306	7.00	8.00
GS-076 306	7.60	8.60
GS-080 306	8.00	9.00
GS-090 306	9.00	10.00

BLIND PLUG FOR DIECAST HOOD

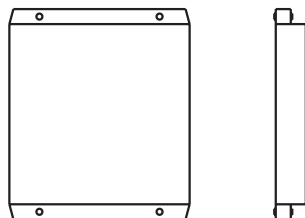

Part Number	Number of contacts
GS-937 308	9 to 37
GS-050 308	50

► ACCESSORIES

TOOLS



Crimping tool



Locating plug



Contact extraction tool

CRIMPING TOOLS			TOOLS		
Contact part number	Crimping tool	Tool turret	Position & Wire section	Insertion	Extraction
010 090 1- 20- OG 010 090 2- 20- GO	Cojack or Oceta M22520/2-01	M 22520/2-08	5 - 0,22mm <sup>2</sup> (24 AWG) 6 - 0,38mm <sup>2</sup> (22 AWG) 7 - 0,60mm <sup>2</sup> (20 AWG)	Not necessary	S_090
	Astro-tool TGV 101	TGV 215	2 - 0,22mm <sup>2</sup> (24 AWG) 3 - 0,38mm <sup>2</sup> (22 AWG) 4 - 0,60mm <sup>2</sup> (20 AWG)		
010 093 1- 22- OG 010 093 2- 22- GO	Cojack or Oceta M22520/2-01	M 22520/2-08	3 - 0,079mm <sup>2</sup> (28 AWG) 4 - 0,12mm <sup>2</sup> (26 AWG)	Not necessary	S_090
	Astro-tool TGV 101	TGV 215	1 - 0,079mm <sup>2</sup> (28 AWG) 2 - 0,12mm <sup>2</sup> (26 AWG)		

FEMALE SCREW LOCK

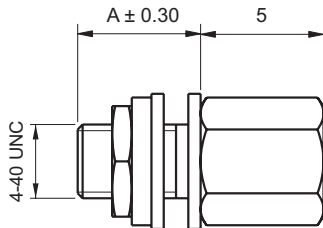

MALE SCREW LOCK WITHOUT HOOD  
CAPTIVE SCREW

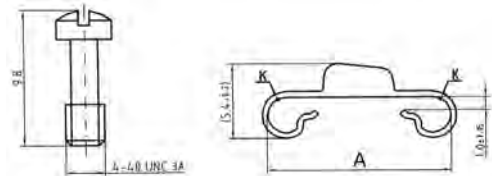

Yellow-chromate finish	
Part number	Dimensions A
GS-002 120	5.00
GS-002 121	6.00
GS-002 122	7.92
GS-002 123	11.00
GS-002 124	13.20
GS-002 125	15.87

Tin plated finish	
Part number	Dimensions A
GS-002 130	5.00
GS-002 131	6.00
GS-002 132	7.92
GS-002 133	11.00
GS-002 134	13.20
GS-002 135	15.87

Part number	Number of contacts	Dimensions A
GS-002 937 115	9 to 37	13.2
GS-002 050 115	50	15.7

DUST CAPS



Male		Female	
Part number	No. contacts	Part number	No. contacts
GS-009-311	9	GS-009-312	9
GS-015-311	15	GS-015-312	15
GS-025-311	25	GS-025-312	25
GS-037-311	37	GS-037-312	37
GS-050-311	50	GS-050-312	50

► BOARD PREPARATION DETAILS FOR STRAIGHT OR 90° TERMINATIONS

25 CONTACTS

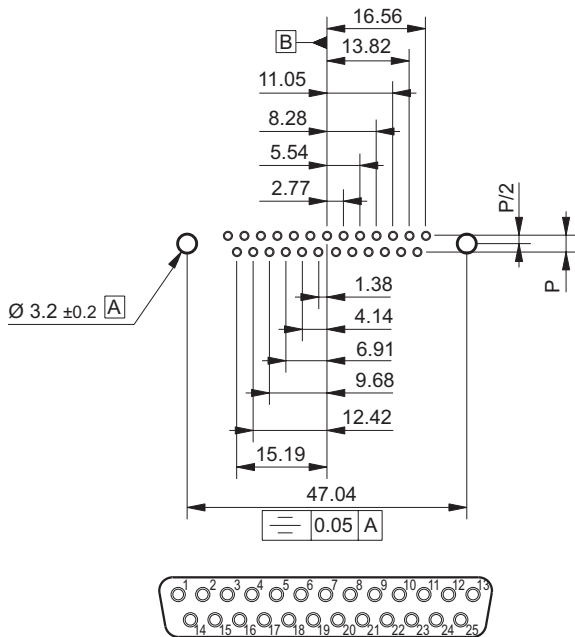

50 CONTACTS

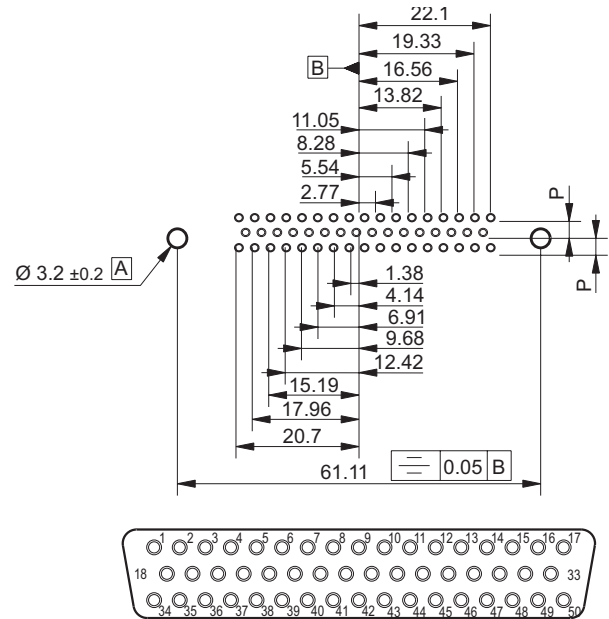

15 CONTACTS

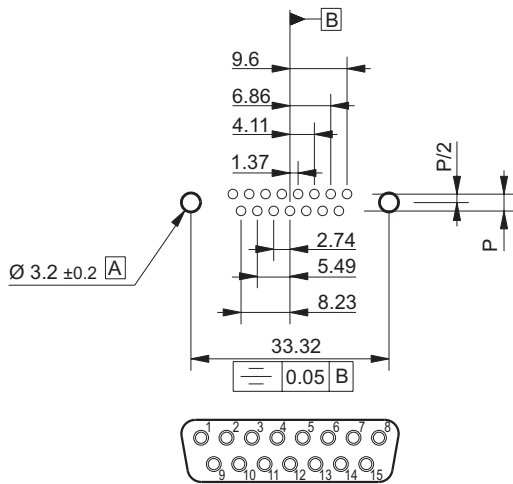

37 CONTACTS

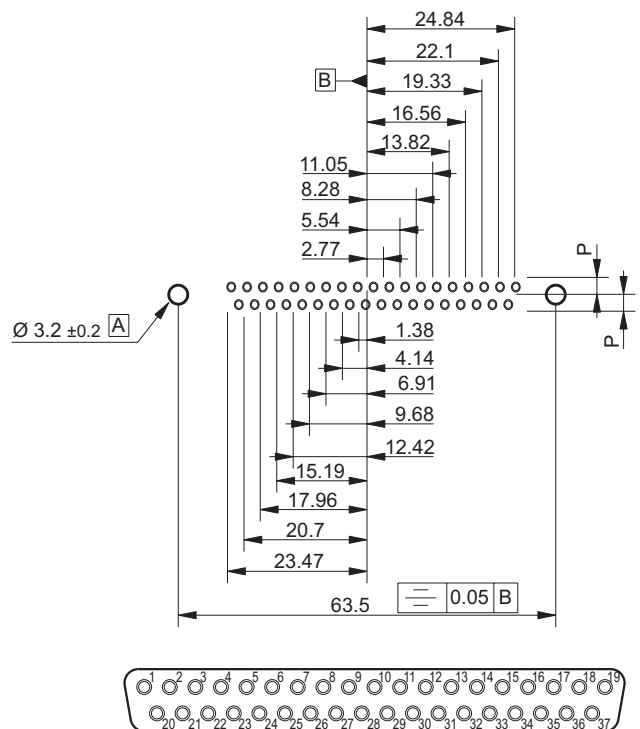

9 CONTACTS

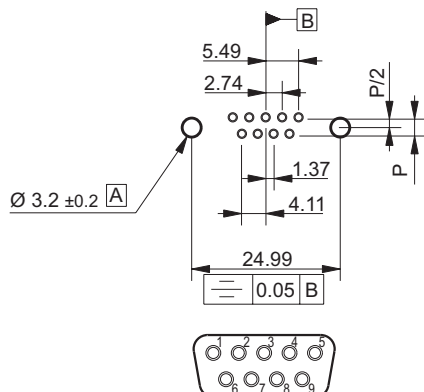

Termination style	P	0.05	A
Straight		2.84	
90°		2.54	

Note: holes Ø 0.1 ⊕ Ø 0.05

# TECHNICAL CHARACTERISTICS

ELECTRICAL		MECHANICAL	
Number of contact	9	Mating cycles	> 500
Contact Ø	Ø1.2mm	Locking system	M3 or UNC 4-40
Current rating	7.5 A	Housing material	Aluminum
Contact resistance	8 mΩ	Shell	Nickel plated
Rated voltage	300V	Contact retention	40N min
Insulation resistance	≥ 5.10 <sup>3</sup> MΩ max	Coding	8 coders (70 coding possibilities)
ENVIRONMENTAL			
Temperature range	-55° C to +100° C	Salt spray	96h
Dry heat	96h at 100°C	Damped heat	21 days (40° C, 90-95% relative humidity)

# HOW TO ORDER



**1** ▶ CONNECTOR FAMILY

**2** ▶ MODEL

**3** ▶ SHELL STYLE (*Salt Spray 96 H*)

**4** ▶ LAYOUT

009

**5** ▶ PART - POLARITY - PLATING

03 PLUG, WITHOUT CONTACTS

04 RECEPTACLE, WITHOUT CONTACTS

13 MALE PLUG, GOLD PLATED TERMINATION

1B MALE PLUG, PRETINNED TERMINATION\*

22 FEMALE RECEPTACLE, GOLD PLATED TERMINATION

2A FEMALE RECEPTACLE, PRETINNED TERMINATION\*

**6** ▶ TERMINATIONS

00 DELIVERED WITHOUT CONTACT

10 RIGHT ANGLE TERMINATION, RECEPTACLE ONLY

20 CRIMP CONTACTS AWG 20 TO 24

22 CRIMP CONTACT AWG 26 TO 28

30 STRAIGHT TERMINATION

40 SOLDER CUP TERMINATION

**7** ▶ CODING

400 CODING UNC 4-40 (*Receptacle*)

401 CODING M3 (*Receptacle*)

A - - CODED HOOD (*Consult us*)

\* Only for PC tail terminations

Dimension are in mm

► CONNECTOR DIMENSIONS

PLUG

RECEPTACLE

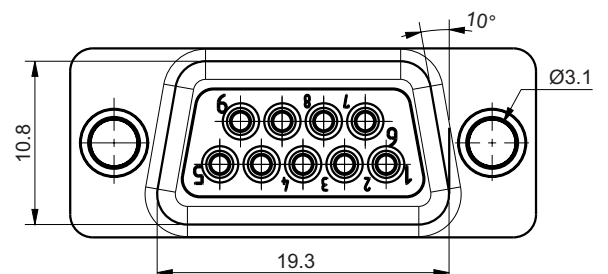
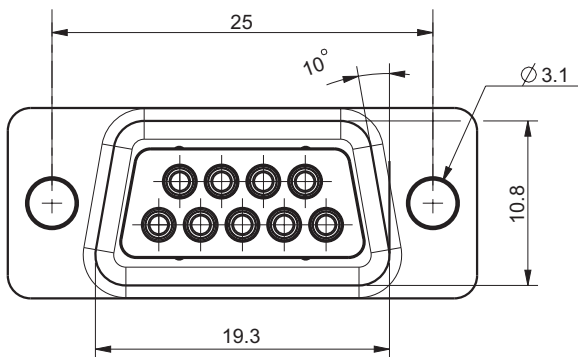
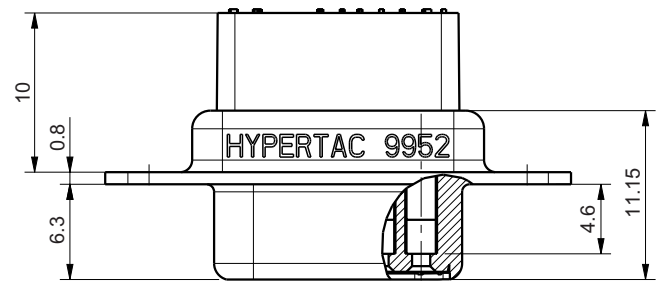
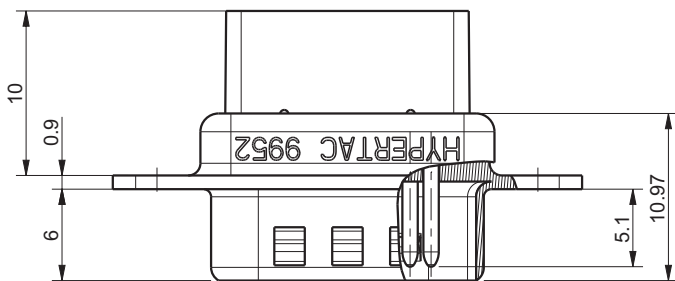
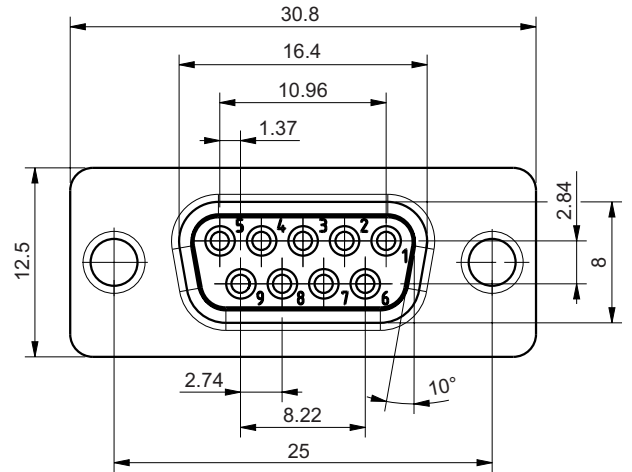
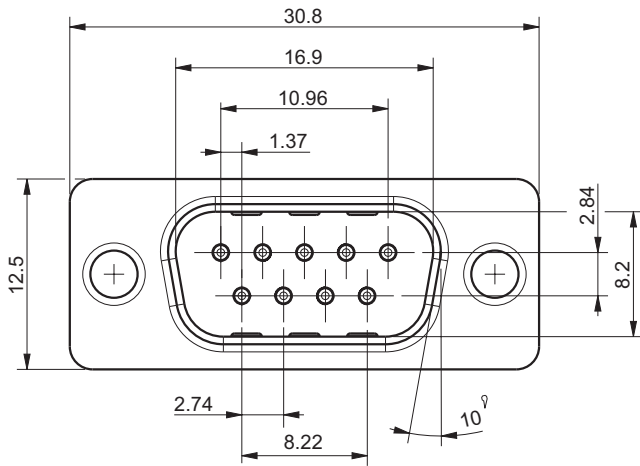

► CODING SYSTEM

UNC 4-40

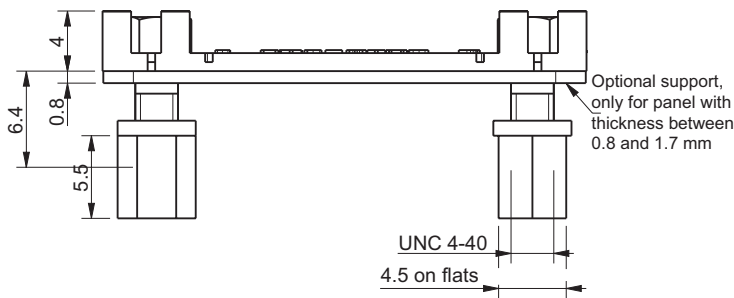

M3

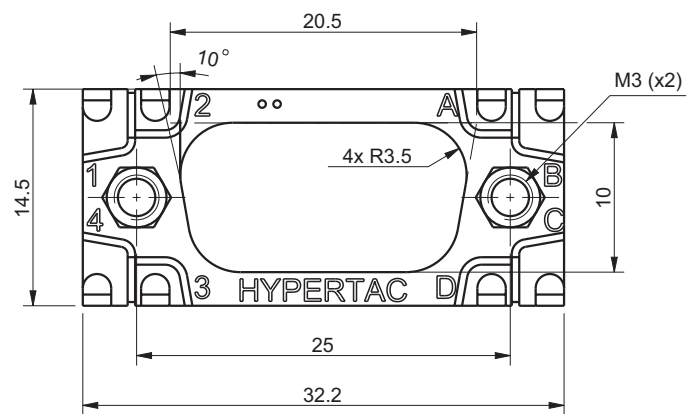
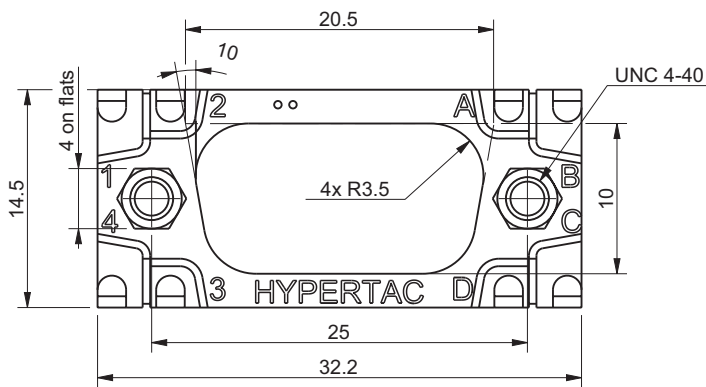
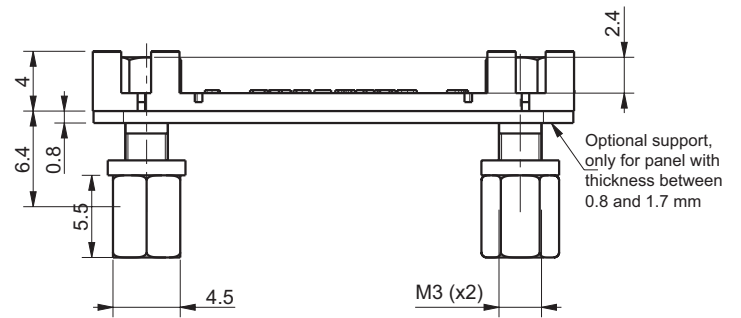
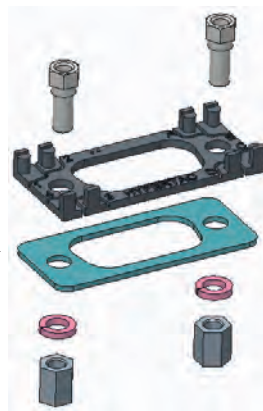

Plate for panel from 0.8 to 1.7mm



Delivered non assembled

▶ EXAMPLE & CODING

PLUG - FRONT VIEW



▶ EXAMPLE & CODING

RECEPTACLE - FRONT VIEW

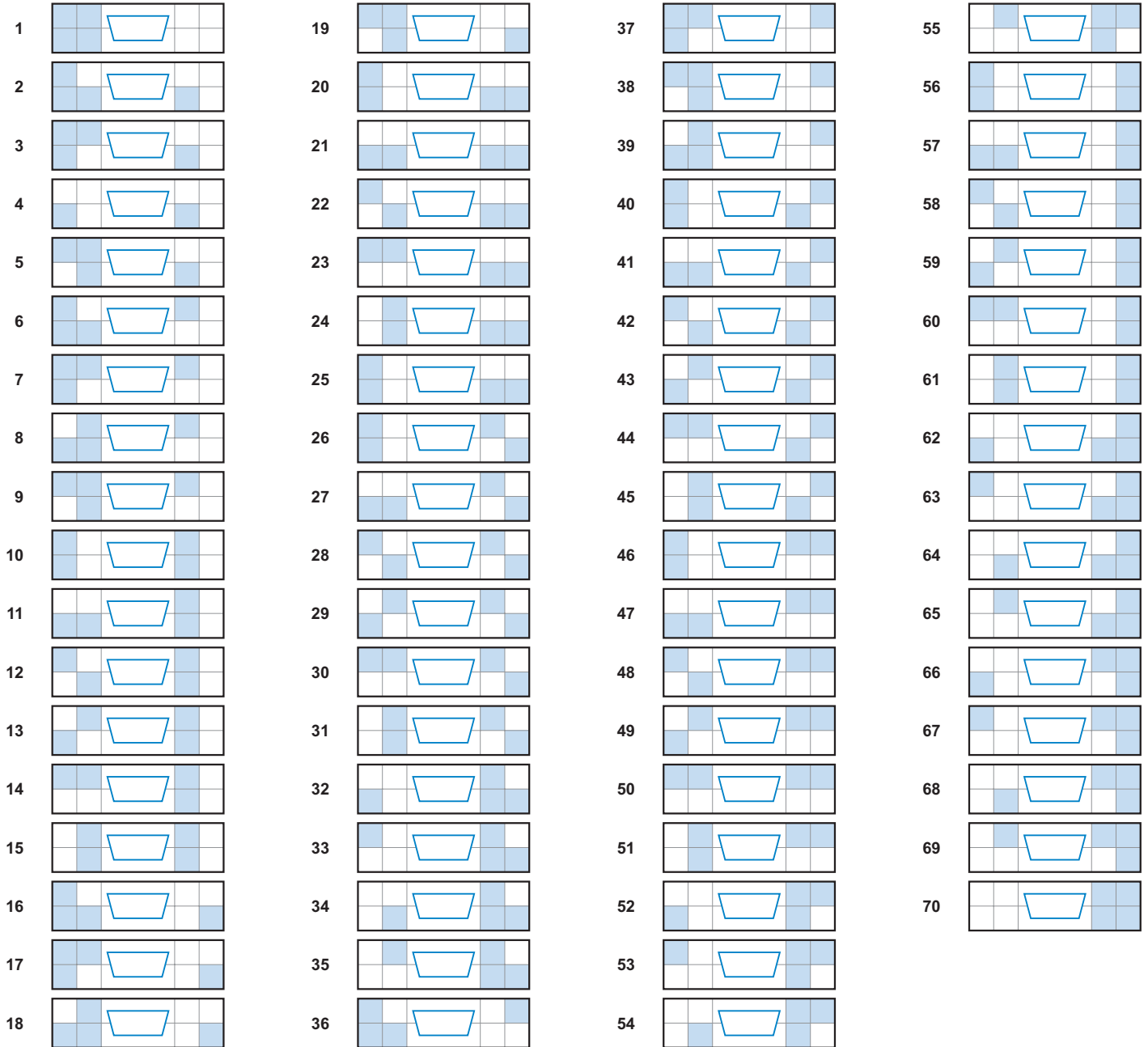



▶ HOOD ACCESSORIES

JACKSCREW

- ▶ Treads: M3 or UNC4-40
- ▶ Hexagon socket head screws
- ▶ Delivered with hoods



Ref: **GSF\_405** for M3  
**GSF\_406** for UNC4-40

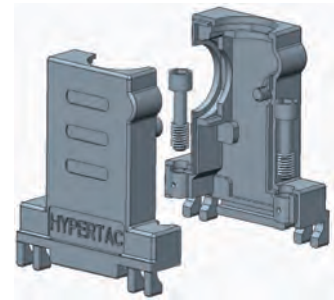

GROMMET SET

- ▶ Material: Thermoplastic
- ▶ Plating: Nickel for shielding

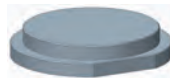

Ref: **GSF\_402**

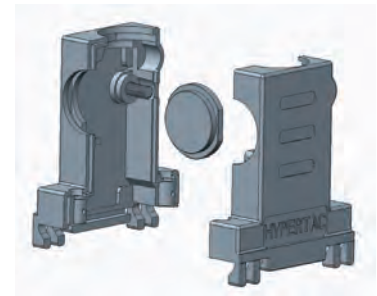

INTERNAL CABLE-CLAMP

- ▶ For cable: Ø6.5 to Ø7.5 mm



Ref: **GSF\_403**

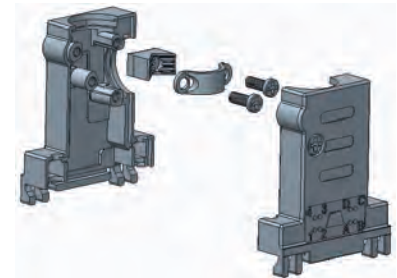

FERRULES

- ▶ Excellent EMI shielding
- ▶ Ø Max cable: 8,6; 7,5; 7; 6 and 5.3
- ▶ Strain relief insert ensure a secure termination



Ref: **GSF\_410** to **GSF\_414**

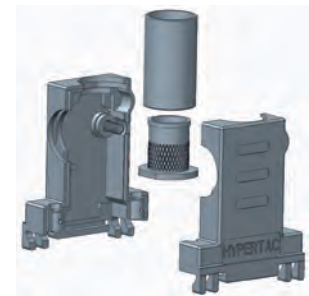

EXTERNAL CABLE-CLAMP

- ▶ For cable : Ø5.3 to Ø7.5mm
- ▶ EMI shielding



Ref: **GSF\_414**

